

CAD FILE :

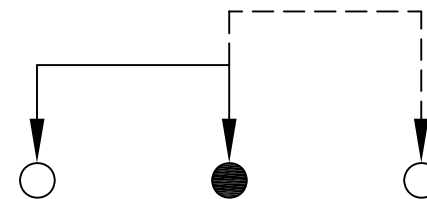

**SCHEMATIC (SHORTING)**

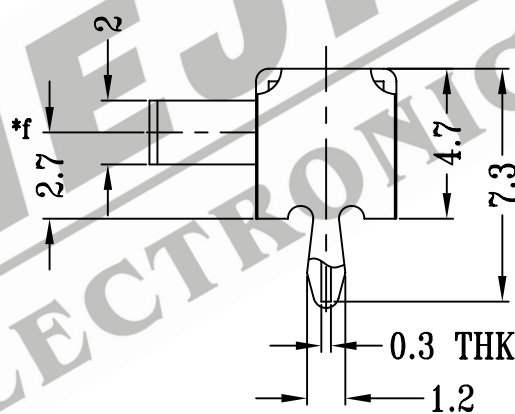
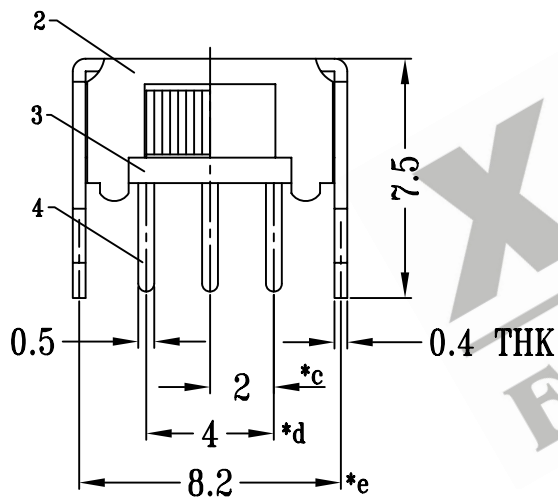
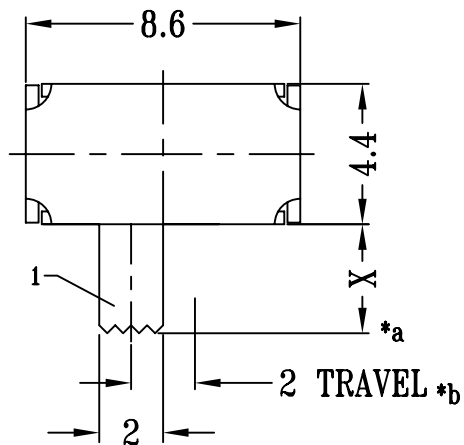
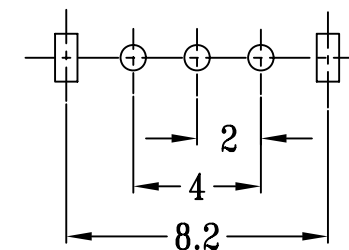

**P.C.B LAYOUT**

注:带\*表示关键尺寸(6个)

8					TOLERANCE UNLESS SPECIFIED	SHENZHEN XIEJIA ELECTRONICS CO.,LTD.				
7										
6	SPRING PLATE	STAINLESS STEEL	1	NATURAL	WITHIN: 1.5±0.1mm	ISSUE	DATE	DESCRIPTIONS OF REVISION		APPD
5	CONTACT CLIP	PBS	1	Ag CLAD	OVER: 1.5±0.2mm					
4	TERMINAL	BRASS STRIP	3	Ag PLATED OVER Ni PLATED	TITLE: HORIZONTAL SLIDE SWITCH	UNIT : mm		DRWG NO : XJ-DR-SK12D23-00		
3	BASE	PHENOLIC RESIN	1	NATURAL	MODEL: SK-12D23	SCALE : 4 : 1		DWN.	ZHOUYU	2005-8-28
2	FRAME	STEEL STRIP	1	Ni PLATED	ALL MATERIALS MUST BE COMPLIANT TO ROHS		CHK'D	FANGYING	2005-8-28	
1	KNOB	POM	1	BLACK			APPD.	KANGXINAN	2005-8-28	
NO.	PARTS	MATERIALS	Q'TY	FINISH						